

# ARB

## Airport Rotating Beacon

Compliances:

- FAA AC 150/5345-12: L-801 & L-802
- ICAO Annex 14



### Features



- ETL Certified
- FAA Approved: L-801 400W  
L-802 1000W
- Metal Halide Lamp (included):  
400W for medium intensity beacons  
1000W for high intensity beacons
- Long Lamp Life
- No Lamp Changer
- Simple Design with few moving parts
- Light weight for easy handling
- 12 RPM, Counter clockwise

### Outline Drawing

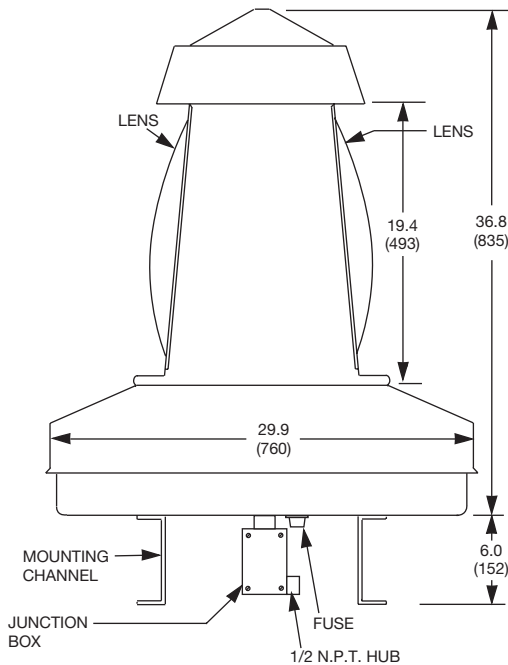

Mounting Channel Bolt Hole Pattern

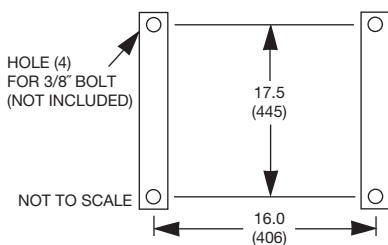

### Ordering Information

Ordering code structure:  -  -

**Fixture Type:** \_\_\_\_\_  
 801 = L-801 Medium Intensity  
 802 = L-802 High Intensity

**Application\*\*:** \_\_\_\_\_  
 A = Airport: White/Green  
 S = Seaplane: White/Yellow  
 H = Heliport: White/Green/Yellow

**Class:** \_\_\_\_\_  
 1 = -35°C  
 2 = -55°C\*

**Power:** \_\_\_\_\_  
 1 = 120V, 60Hz  
 2 = 220V, 50Hz

**Options:** \_\_\_\_\_  
 BC = Low-Angle Beam Cutoff 2°  
 TR = Tell-Tale Relay with 250W Quartz Lamp  
 WW = Two White Lenses

\* All Class 2 ARB's require the TR option  
 \*\* Standard Application - Options Available

<b>Dimensions:</b>	inches (mm)	<b>Shipping Weight:</b>	243 Lbs. 110 kg.
<b>Instruction Manual:</b>	9218 (802XX) 9301 (801XX)	<b>Shipping Volume:</b>	47.5 cu.ft. 1.345 cu.m.

## Photometric Data

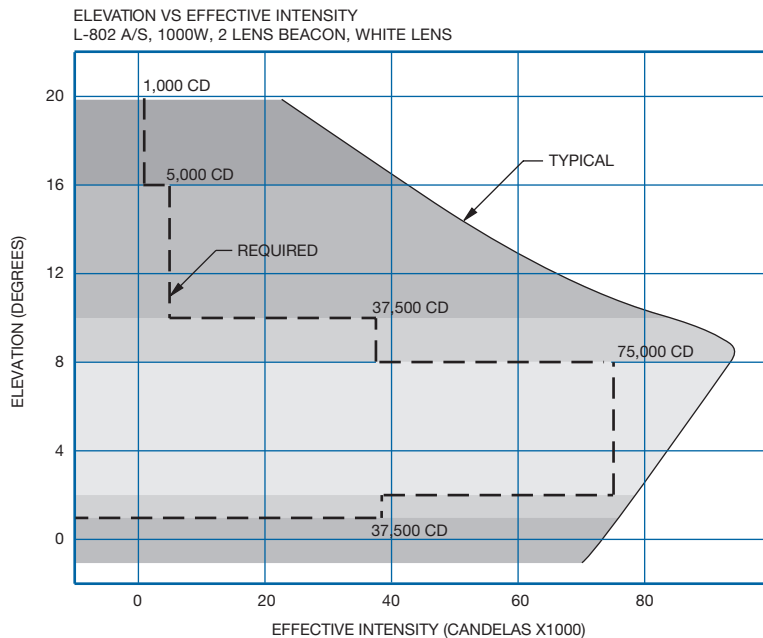

Notes:

1. Beacon Rotates:
  - 12 RPM @ 60Hz
  - 10 RPM @ 50Hz
2. Flash Rate: (L-801H)
  - 36 Flashes/min @ 60Hz
  - 30 Flashes/min @ 50Hz
3. Flash Rate: (L-802 A/S)
  - 24 Flashes/min @ 60Hz
  - 20 Flashes/min @ 50Hz

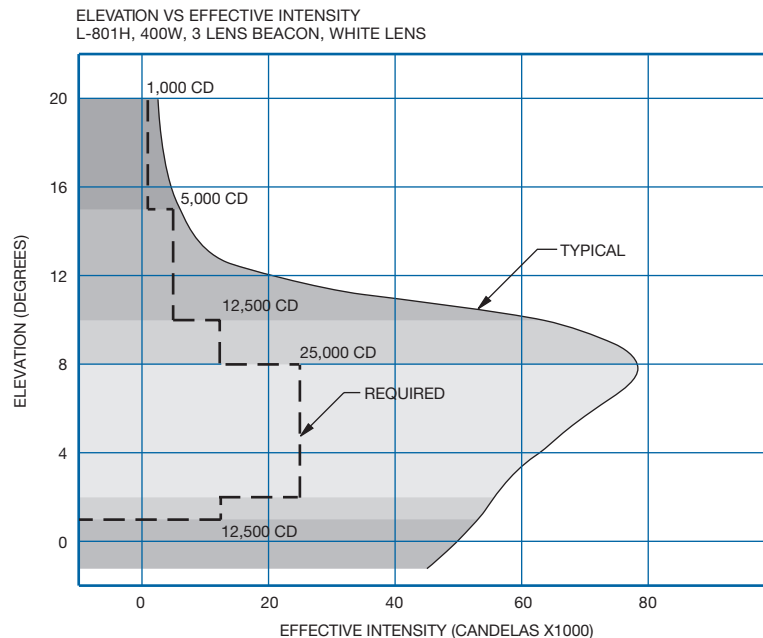

## Renewal Parts

Description	Part Number	Description	Part Number
Ballast Assembly, 1000W, 120V, 60Hz	65058-1	Green Lens	65020-2
Ballast Assembly, 1000W, 220V, 50Hz	65058-2	Lamp, 1000W Metal Halide (802XX)	10047-2795
Ballast Assembly, 400W, 120V, 60Hz	65058-3	Lamp, 400W Metal Halide (801XX)	10047-1802
Ballast Assembly, 400W, 220V, 50Hz	65058-4	Motor Assembly	65057
Clear Lens (1000W ARB)	65020-1	Relay Assembly, TR option	65045
Clear Lens (400W ARB)	65020-4	Tell-Tale Lamp, 250W Quartz (Option TR)	10047-2293
Fuse, F1	10047-2344	Yellow Lens	65020-3
Gearing Assembly	65018		

